

Imaging of Motor Activity in Freely Moving Subjects Using a Wearable NIRS Imaging System



Christoph H. Schmitz, PhD^{1,2}

¹Charité University Medicine Berlin

¹NIRx Medizintechnik GmbH, Berlin

OSA BIOMED 2012
Miami, FL, USA



How to miniaturize NIRS? (And, why?)

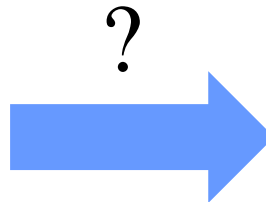
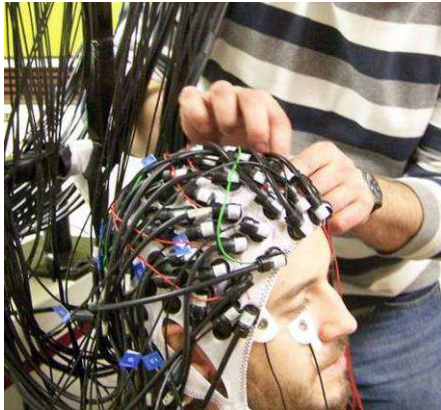

- Natural environment
- Sports, physical therapy
- Children
- Bedside
- Wireless
- ...



Direct Illumination

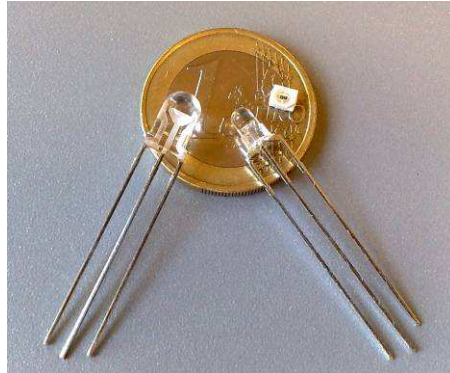

- LED
 - Wavelengths 760 nm, 850 nm
 - Radiated Power $\sim 10 \text{ mW} / \lambda$
- Pros
 - Size, cost
 - Stable operation easy
- Cons
 - $\sim 30 \text{ nm}$ spectral width
 - Diffuse
 - (Drift)

Direct Detection

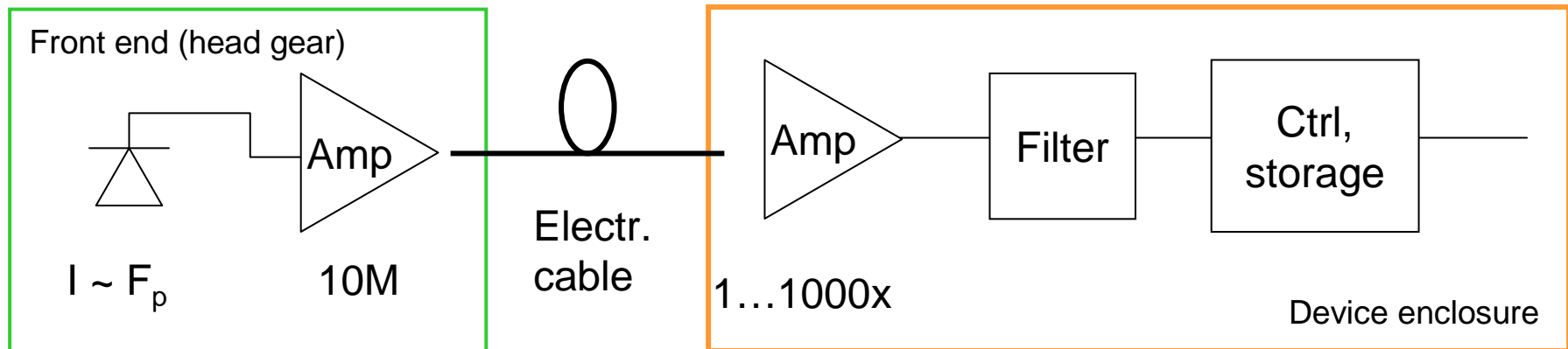
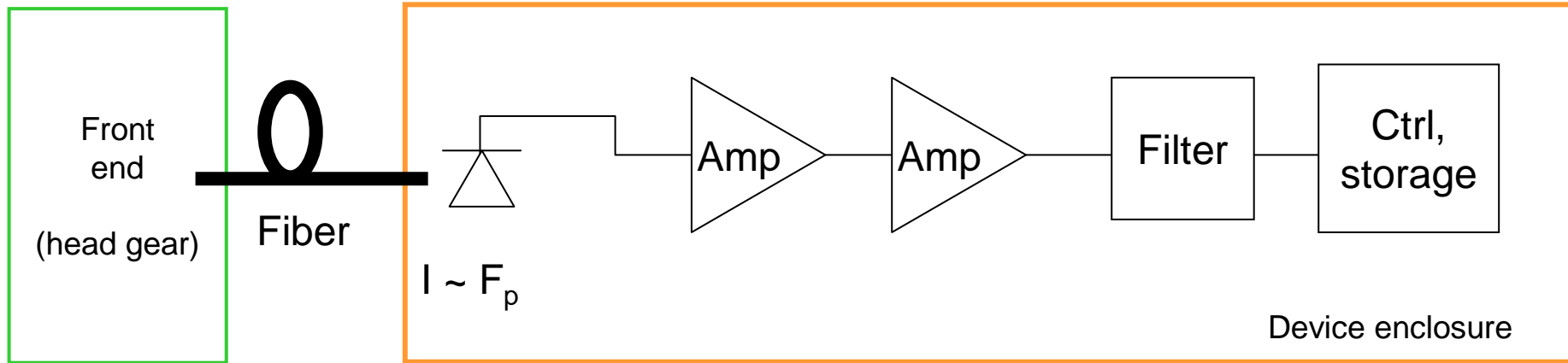

Active Sensor

LED Illumination



Detector

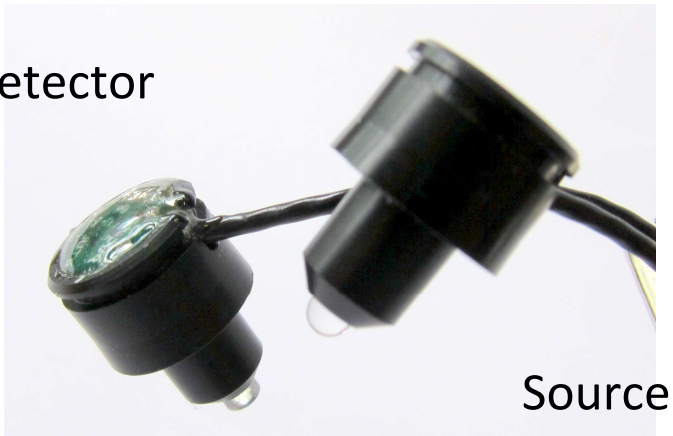

Source

● 4.0 mm

● 1.4 mm

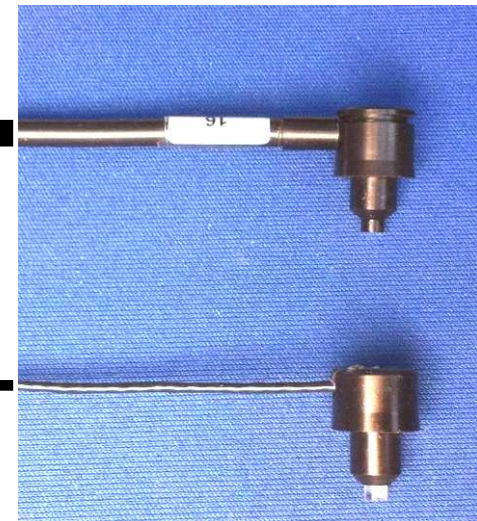

Portable NIRS Acquisition Unit



Bicycle Experiment



- Controlled left-hand gripping ($\sim 1..2$ Hz) during bicycle riding
- 20 sec activation / 40 sec pause / 10 trials
- N = 7 subjects

Experimental Conditions

Condition 1

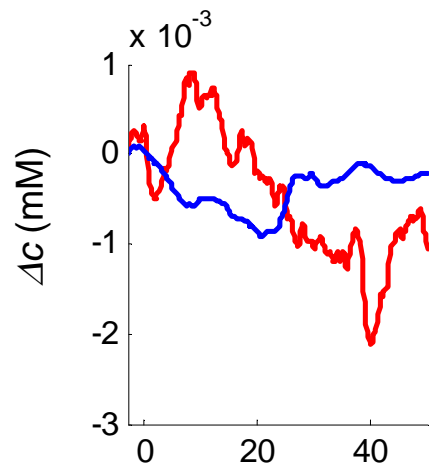

Condition 2

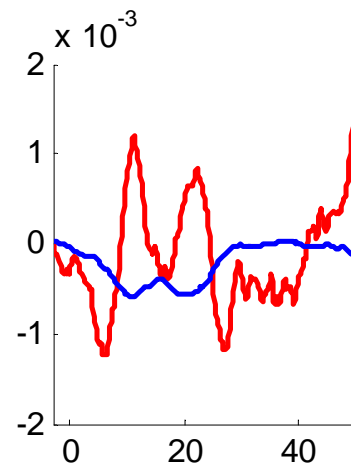

Condition 3

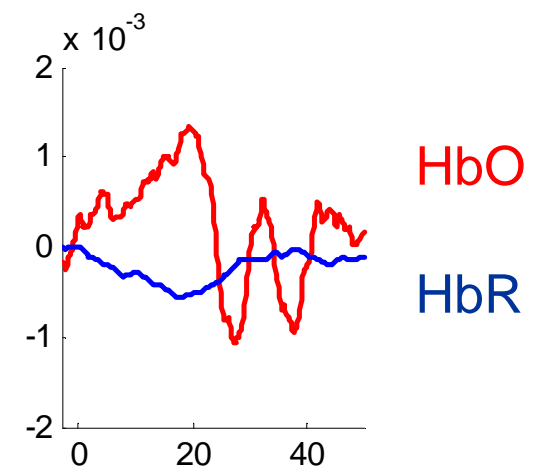

Signal Quality



Weak Artifacts

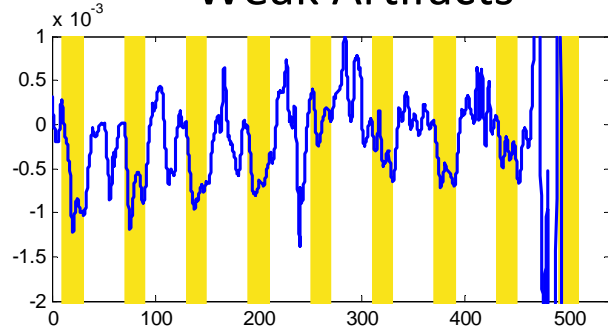

Strong Artifacts

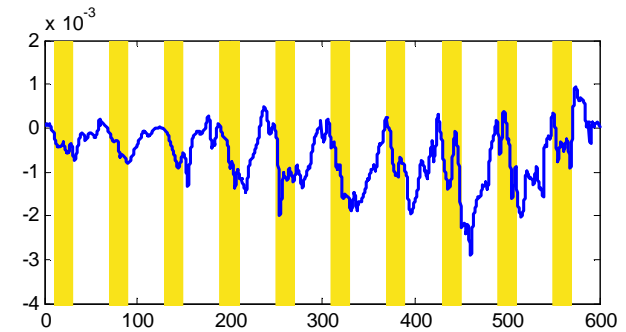
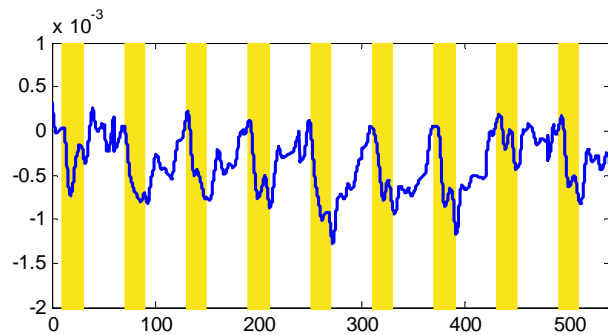
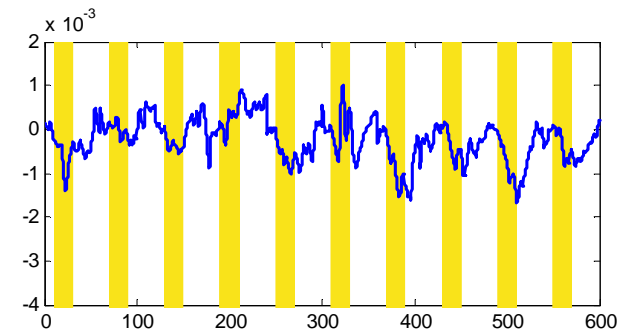
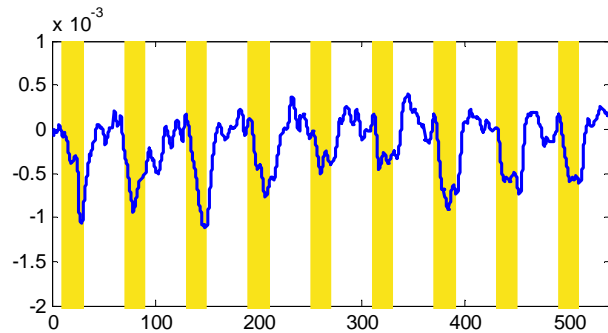
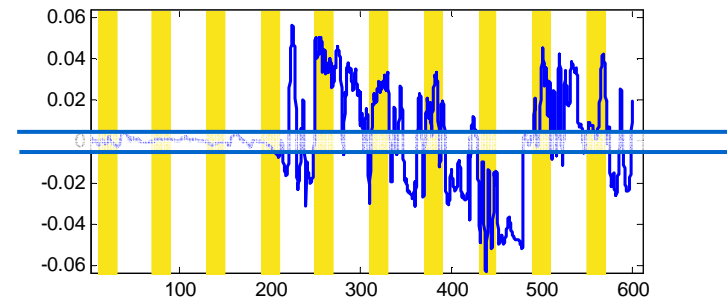

Spatial Mapping

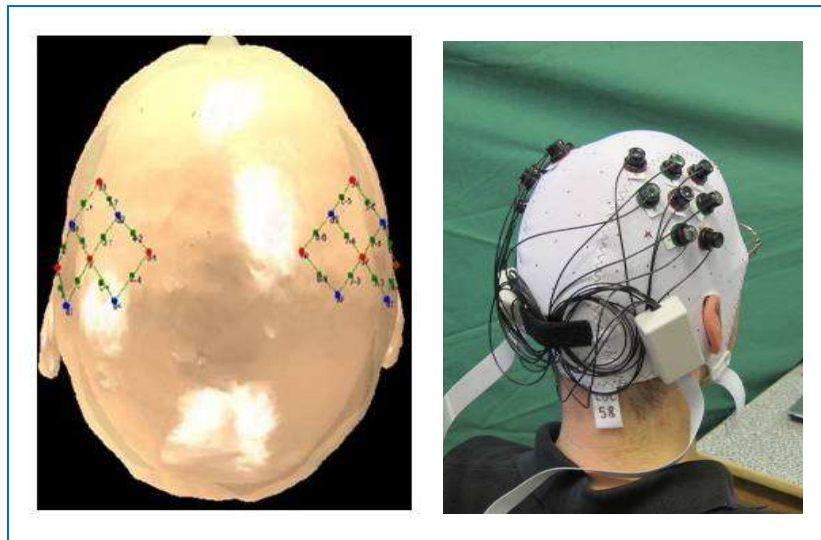
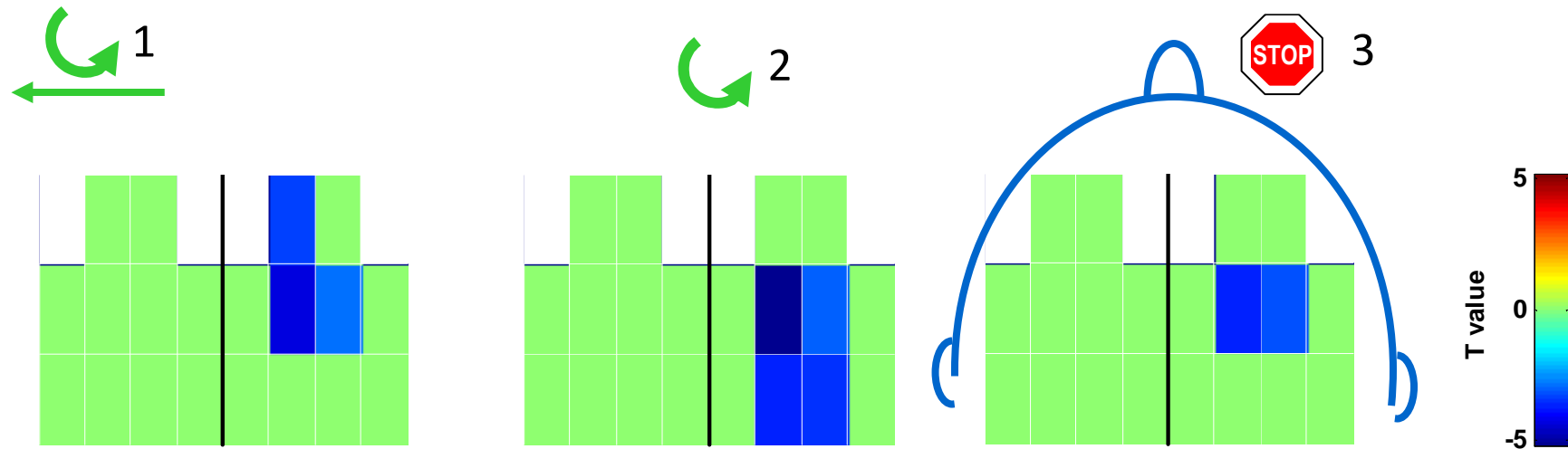

Threshold @ $p = 0.0065$

(Accounts for false discovery rate)

Anatomical Mapping



Cond. 1

Cond. 2

Cond. 3

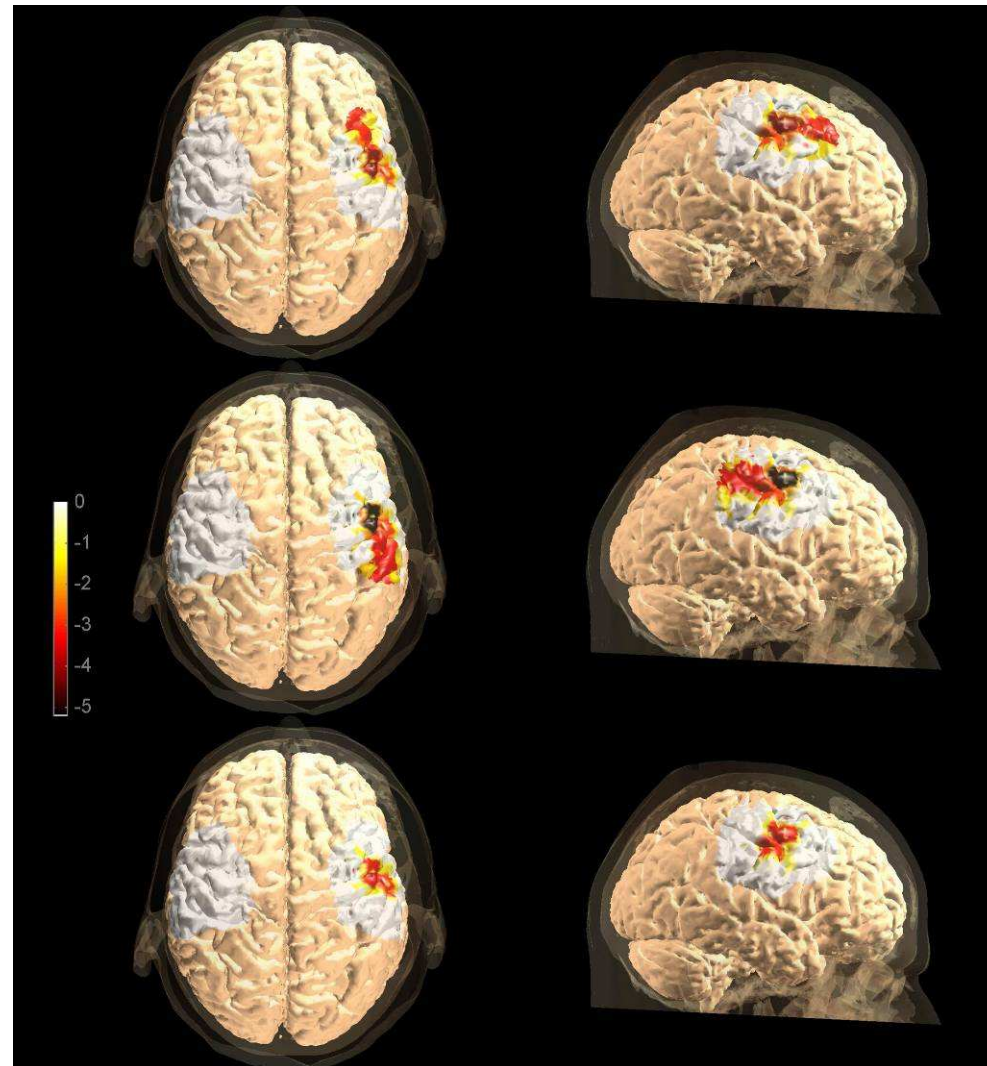

Summary & Outlook

- Miniaturized active sensors
- Integrated multi-channel NIRS System into portable device (Wifi)
- Demonstrated robustness
- Demonstrated real-world untethered experiments

What next?

- More subjects
- More experiments → new kind of physiological data
- More channels
- Multimodal integration

Charité NIRS Team:

A. Krüger

S. P. Koch

J. Mehnert

C. Habermehl

S. Piper

J. Steinbrink

H. Obrig

